

DISCLAIMER:

The content and the product for sale is based upon the author's opinion and is provided solely on an "as is" and "as available" basis. All products from jqqpi gpgtcvqt.com are strictly for informational purposes only and should not to be construed to be professional advice from us. We do not guarantee the accuracy or completeness of any of the information provided, and is not responsible for any loss resulting from your reliance on such information. We do not assume any responsibility for errors, omissions or contrary interpretation of the subject matter herein via this website or in the product. Under no circumstances will we be liable or responsible for any direct, indirect, incidental, consequential (including damages from loss of business, lost profits, litigation, or the like), special, exemplary, punitive, or other damages, under any legal theory, arising out of or in any way relating to our website, your website use, or the content, even if advised of the possibility of such damages. This is an online information service, subject to your compliance with the terms and conditions set forth below.

Copyright, licenses and idea submissions

The entire contents of the site are protected by international copyright and trademark laws. The owner of the copyrights and trademarks are jqqpi gpgtcvqt.com, its affiliates or other third party licensors. You may not modify, copy, reproduce, republish, upload, post, transmit, or distribute, in any manner, the material on the site, including text, graphics, code and/or software. You may print and download portions of material from the different areas of the site solely for your own non-commercial use provided that you agree not to change or delete any copyright or proprietary notices from the materials. You agree to grant to jqqpi gpgtcvqt.com a non-exclusive, royalty-free, worldwide, perpetual license, with the right to sub-license, to reproduce, distribute, transmit, create derivative works of, publicly display and publicly perform any materials and other information (including, without limitation, ideas contained therein for new or improved products and services) you submit to any public areas of the site (such as bulletin boards, forums and newsgroups) or by e-mail to jqqpi gpgtcvqt.com by all means and in any media now known or hereafter developed.

Limitation of liability

In no event will jqqpi gpgtcvqt.com be liable for any incidental, consequential, or indirect damages (including, but not limited to, damages for loss of profits, business interruption, loss of programs or information, and the like) arising out of the use of or inability to use the service, or any information, or transactions provided on the service, or downloaded from the service, or any delay of such information or service. Even jqqpi gpgtcvqt.com or its authorized representatives have been advised of the possibility of such damages, or any claim attributable to errors, omissions, or other inaccuracies in the service and/or materials or information downloaded through the service. Because some states do not allow the exclusion or limitation of liability for consequential or incidental damages, the above limitation may not apply to you. In such states hoongenerator.com liability is limited to the greatest extent permitted by law.

Any rights not expressly granted herein are reserved.

Air and Air Pressure

Air represents the "invisible gases that make up the atmosphere". The word comes from Old French *air* (atmosphere, breeze, weather), from Latin *aerem* (nominative *aer*) "air, lower atmosphere, sky" from Greek *aer* (genitive *aeros*) "air" (related to *aenai* "to blow, breathe"), which is of unknown origin, possibly from a base **awer* - and thus related to *aeirein* "to raise" and *arteria* "windpipe, artery" (see *aorta*) on notion of "lifting, that which rises." In Homer mostly "thick air, mist;" later "air" as one of the four elements.



Atmosphere of Earth

The **atmosphere of Earth** is the layer of gases, commonly known as **air** that surrounds the planet Earth and is retained by Earth's gravity.

The atmosphere protects life on Earth by absorbing ultraviolet solar radiation, warming the surface through heat retention (greenhouse effect), and reducing temperature extremes between day and night (the diurnal temperature variations).

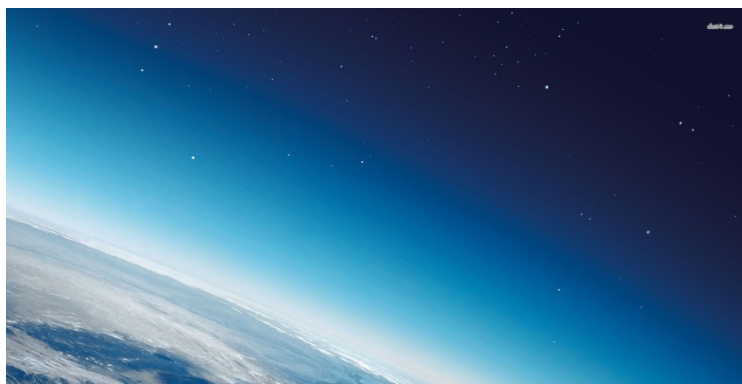

By volume, dry air contains 78.09% nitrogen, 20.95% oxygen, 0.93% argon, 0.039% carbon dioxide, and small amounts of other gases. Air also contains a variable amount of water vapor, on average around 1% at sea level, and 0.4% over

the entire atmosphere. Air content and atmospheric pressure vary at different layers, and air suitable for use in photosynthesis by terrestrial plants and breathing of terrestrial animals is found only in Earth's troposphere and in artificial atmospheres.

The atmosphere has a mass of about 5.15×10^{21} kg, three quarters of which is within about 11 km (36,000 ft.) of the surface. The atmosphere becomes thinner and thinner with increasing altitude, with no definite boundary between the atmosphere and outer space. The Kármán line, at 100 km (62 mi), or 1.57% of Earth's radius, is often used as the border between the atmosphere and outer space. Atmospheric effects become noticeable during atmospheric reentry of spacecraft at an altitude of around 120 km (75 mi). Several layers can be distinguished in the atmosphere, based on characteristics such as temperature and composition.

The study of Earth's atmosphere and its processes is called atmospheric science (aerology). Early pioneers in the field include Léon Teisserenc de Bort and Richard Assmann.

Composition

The three major constituents of air, and therefore of Earth's atmosphere, are nitrogen, oxygen, and argon. Water vapor accounts for roughly 0.25% of the atmosphere by mass. The concentration of water vapor (a greenhouse gas) varies significantly from around 10 ppm by volume in the coldest portions of the atmosphere to as much as 5% by volume in hot, humid air masses, and concentrations of other atmospheric gases are typically quoted in terms of dry air (without water vapor). The remaining gases are often referred to as trace gases, among which are the greenhouse gases, principally carbon dioxide, methane, nitrous oxide, and ozone. Filtered air includes trace amounts of many other chemical compounds. Many substances of natural origin may be present in locally and seasonally variable small amounts as aerosols in an unfiltered air sample, including dust of mineral and organic composition, pollen and spores, sea spray, and volcanic ash. Various industrial pollutants also may be present as gases or aerosols, such as chlorine (elemental or in compounds), fluorine compounds and elemental mercury vapor. Sulfur compounds such as hydrogen sulfide and sulfur dioxide (SO₂) may be derived from natural sources or from industrial air pollution.

Principal layers

In general, air pressure and density decrease with altitude in the atmosphere. However, temperature has a more complicated profile with altitude, and may remain relatively constant or even increase with altitude in some regions (see the temperature section, below). Because the general pattern of the temperature/altitude profile is constant and measurable by means of instrumented balloon soundings, the temperature behavior provides a useful metric to distinguish atmospheric layers. In this way, Earth's atmosphere can be divided (called atmospheric stratification) into five main layers. Excluding the exosphere, Earth has four primary layers, which are the troposphere, stratosphere, mesosphere, and thermosphere. From highest to lowest, the five main layers are:

- Exosphere: 700 to 10,000 km (440 to 6,200 miles)
- Thermosphere: 80 to 700 km (50 to 440 miles)
- Mesosphere: 50 to 80 km (31 to 50 miles)
- Stratosphere: 12 to 50 km (7 to 31 miles)
- Troposphere: 0 to 12 km (0 to 7 miles)

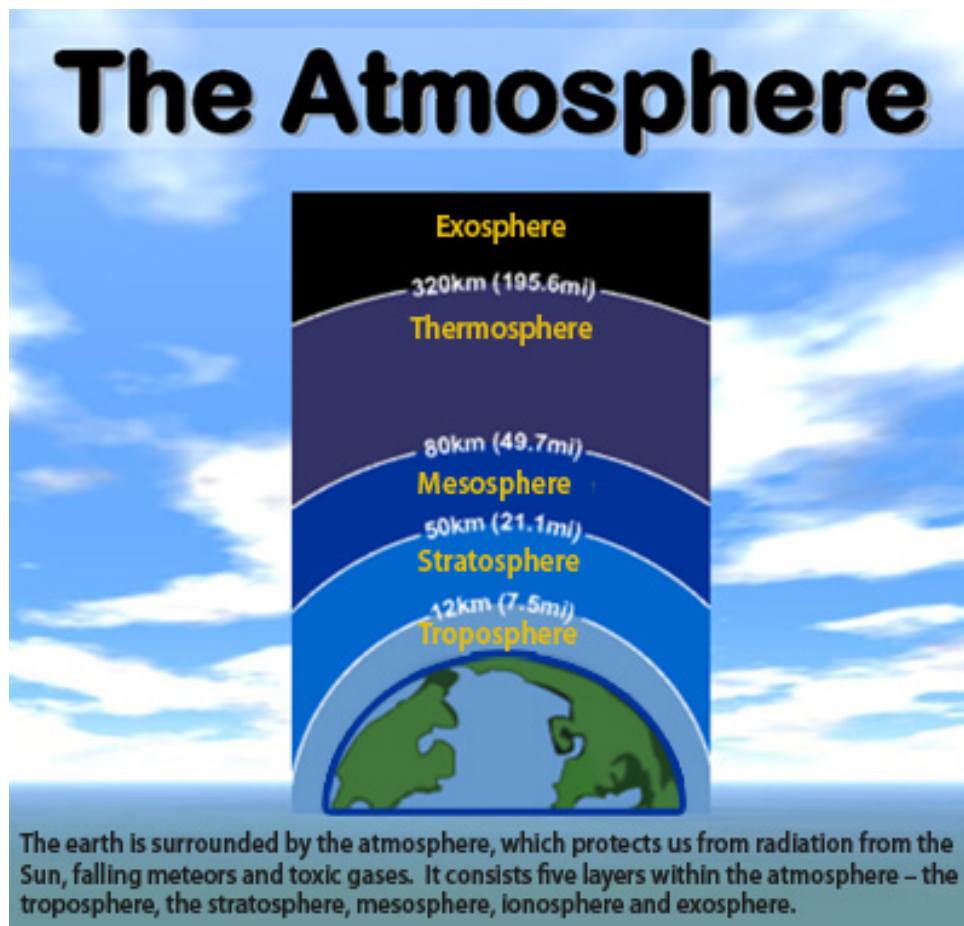

Other layers

Within the five principal layers that are largely determined by temperature, several secondary layers may be distinguished by other properties:

- The ozone layer is contained within the stratosphere. In this layer ozone concentrations are about 2 to 8 parts per million, which is much higher than in the lower atmosphere but still very small compared to the main components of the atmosphere. It is mainly located in the lower portion of the stratosphere from about 15–35 km (9.3–21.7 mi;

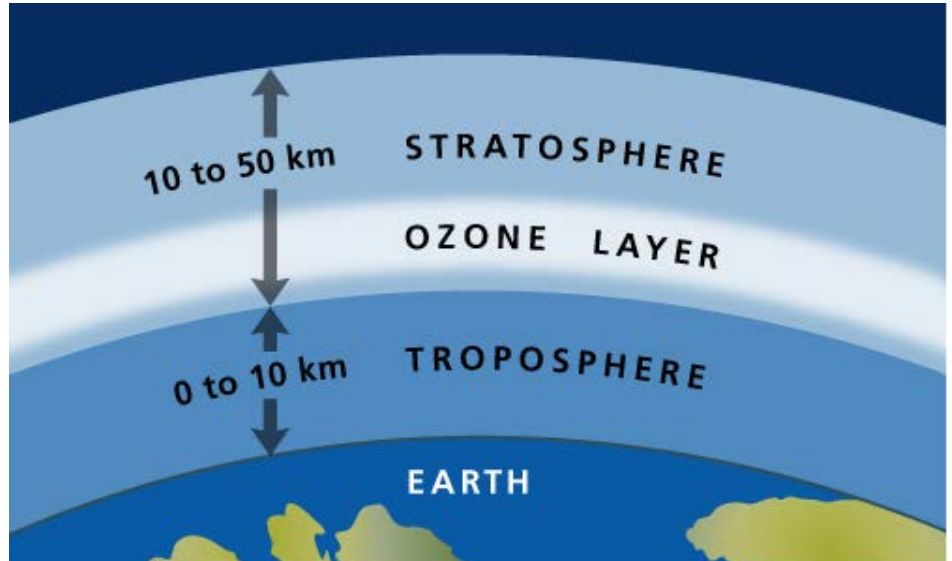

49,000–115,000 ft.), though the thickness varies seasonally and geographically. About 90% of the ozone in Earth's atmosphere is contained in the stratosphere.

- The ionosphere is a region of the atmosphere that is ionized by solar radiation. It is responsible for auroras. During daytime hours, it stretches from 50 to 1,000 km (31 to 621 mi; 160,000 to 3,280,000 ft.) and includes the

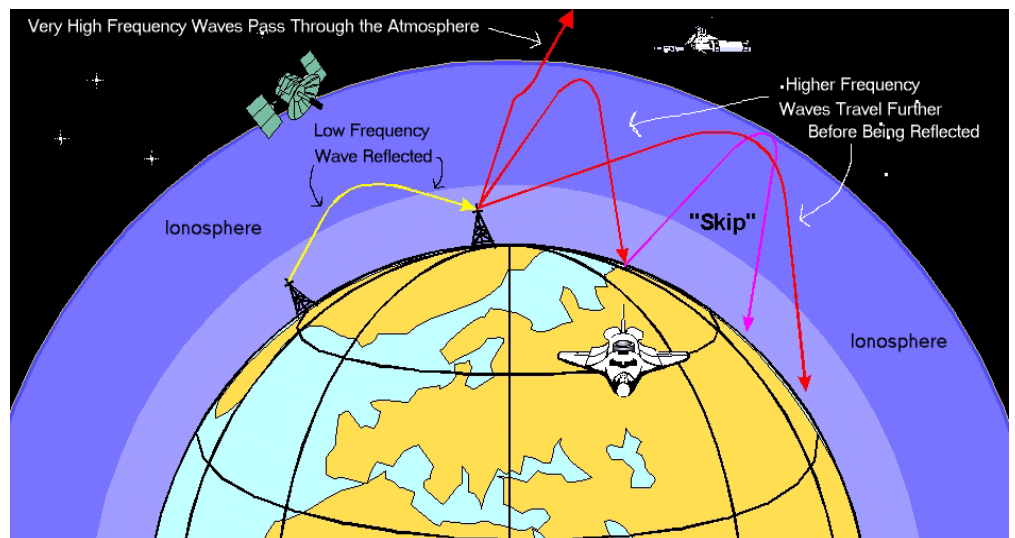

mesosphere, thermosphere, and parts of the exosphere. However, ionization in the mesosphere largely ceases during the night, so auroras are normally seen only in the thermosphere and lower exosphere. The ionosphere forms the inner edge of

the magnetosphere. It has practical importance because it influences, for example, radio propagation on Earth.

- The homosphere and heterosphere are defined by whether the atmospheric gases are well mixed. The surface-based homosphere includes the troposphere, stratosphere, mesosphere, and the lowest part of the thermosphere, where the chemical composition of the atmosphere does not depend on molecular weight because the gases are mixed by turbulence.^[18] This relatively homogeneous layer ends at the turbopause found at about 100 km (62 mi; 330,000 ft), which places it about 20 km (12 mi; 66,000 ft) above the mesopause. Above this altitude lies the heterosphere, which includes the exosphere and most of the thermosphere. Here, the chemical composition varies with altitude. This is because the distance that particles can move without colliding with one another is large compared with the size of motions that cause mixing. This allows the gases to stratify by molecular weight, with the heavier ones, such as oxygen and nitrogen, present only near the bottom of the heterosphere. The upper part of the heterosphere is composed almost completely of hydrogen, the lightest element.

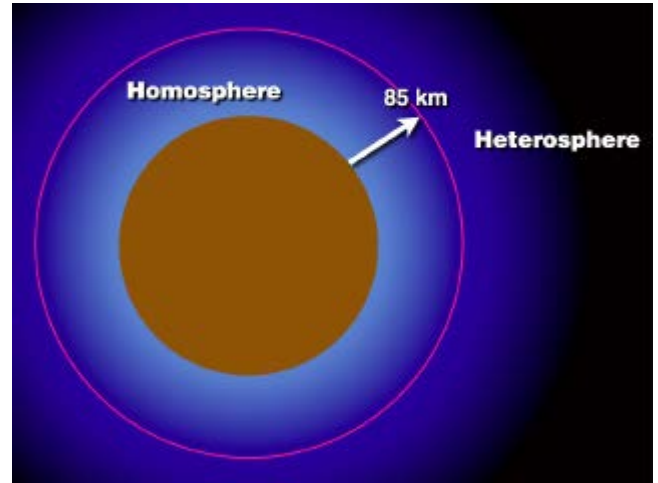

- The planetary boundary layer is the part of the troposphere that is closest to Earth's surface and is directly affected by it, mainly through turbulent diffusion. During the day the planetary boundary layer usually is well-mixed, whereas at night it becomes stably stratified with weak or intermittent mixing. The depth of the planetary boundary layer ranges from as little as about 100 meters on clear, calm nights to 3000 m or more during the afternoon in dry regions.

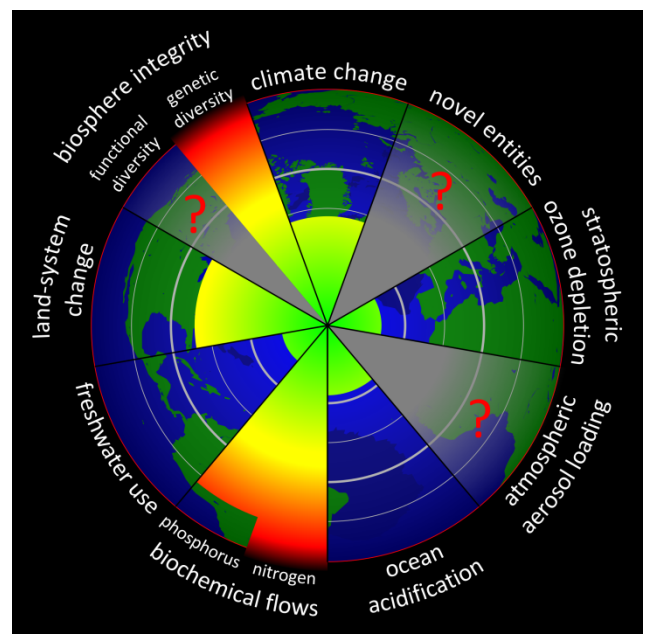

The average temperature of the atmosphere at Earth's surface is 14 °C (57 °F; 287 K) or 15 °C (59 °F; 288 K), depending on the reference.

Pressure and thickness

The average atmospheric pressure at sea level is defined by the International Standard Atmosphere as 101325 pascals (760.00 Torr; 14.6959 psi; 760.00 mmHg). This is sometimes referred to as a unit of standard atmospheres (atm). Total atmospheric mass is 5.1480×10^{18} kg (1.135×10^{19} lb), about 2.5% less than would be inferred from the average sea level pressure and Earth's area of 51007.2 megahectares, this portion being displaced by Earth's mountainous terrain. Atmospheric pressure is the total weight of the air above unit area at the point where the pressure is measured. Thus air pressure varies with location and weather.

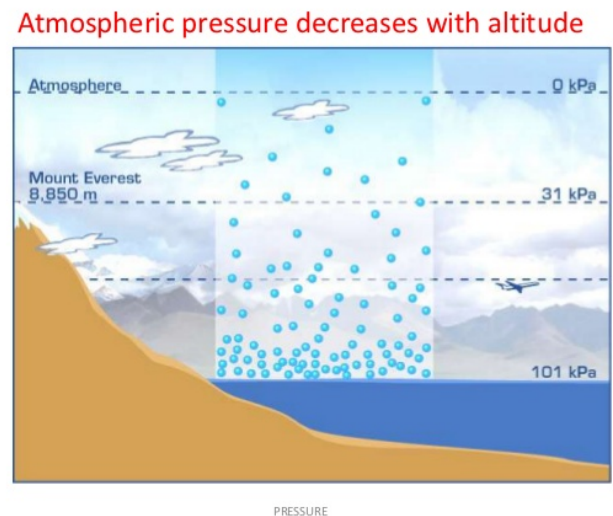

If the entire mass of the atmosphere had a uniform density from sea level, it would terminate abruptly at an altitude of 8.50 km (27,900 ft). It actually decreases exponentially with altitude, dropping by half every 5.6 km (18,000 ft) or by a factor of $1/e$ every 7.64 km (25,100 ft), the average scale height of the atmosphere below 70 km (43 mi; 230,000 ft). However, the atmosphere is more accurately modeled with a customized equation for each layer that takes gradients of temperature, molecular composition, solar radiation and gravity into account.

In summary, the mass of Earth's atmosphere is distributed approximately as follows:

- 50% is below 5.6 km (18,000 ft).
- 90% is below 16 km (52,000 ft).
- 99.99997% is below 100 km (62 mi; 330,000 ft.), the Kármán line. By international convention, this marks the beginning of space where human travelers are considered astronauts.

By comparison, the summit of Mt. Everest is at 8,848 m (29,029 ft); commercial airliners typically cruise between 10 km (33,000 ft) and 13 km (43,000 ft) where the thinner air improves fuel economy; weather balloons reach 30.4 km (100,000 ft) and above; and the highest X-15 flight in 1963 reached 108.0 km (354,300 ft).

Even above the Kármán line, significant atmospheric effects such as auroras still occur. Meteors begin to glow in this region, though the larger ones may not burn up until they penetrate more deeply. The various layers of Earth's ionosphere, important to HF radio propagation, begin below 100 km and extend beyond 500 km. By comparison, the International Space Station and Space Shuttle typically orbit at 350–400 km, within the F-layer of the ionosphere where they encounter enough atmospheric drag to require reboosts every few months. Depending on solar activity, satellites can experience noticeable atmospheric drag at altitudes as high as 700–800 km.

Next, we will present how the air surrounding us can help you juice more power out of the Hoon Generator. Simply follow these steps and, remember, keep it safe!

THE EXTRA AIR SPIN

First you need to attach at least 4 paddles to the aluminum thread of the J qqp Generator, as shown in the picture:

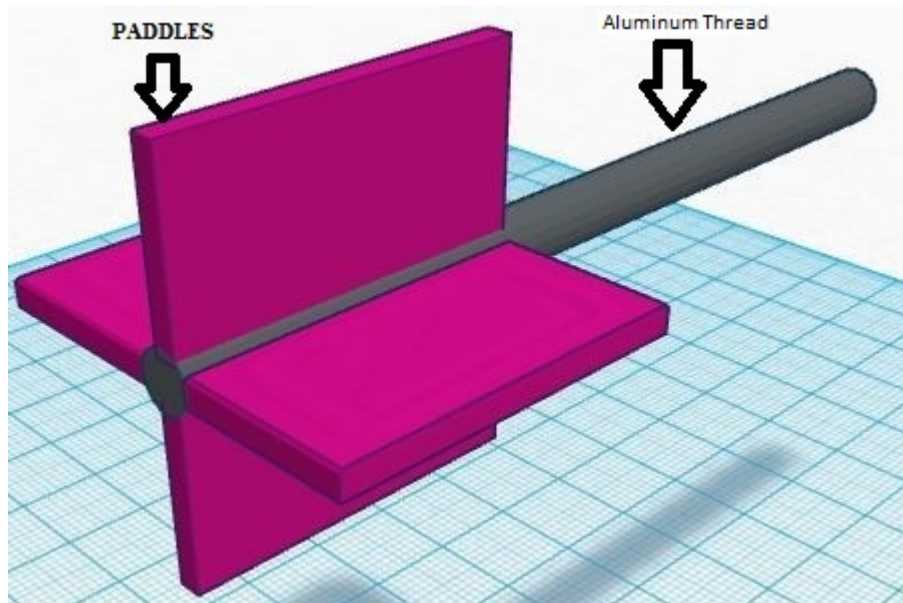

You can attach the paddles using any means but you need to make sure they will be well set because they will be subjected to high pressure and will reach many RPMs. We recommend welding them to the driveshaft.

Next, we will present the steps to build an air compressor to provide the strong air flow onto the paddles.



You will need some air valves and compressor parts. You can find them at any local store:

The important thing is the main idea on how to build it.

1. Air compressor



This is the first and the basic thing that you'll need.

There are two ways to get a fridge compressor you want to turn into an air compressor:

- A) Buy a salvaged compressor
- B) Salvage one yourself from an old fridge

In case you choose option B then you have to remove the compressor from the fridge yourself - that process is described in the next step. If you already have a salvaged compressor, then go to step 2.

Typical fridge compressors are 100 - 300 watt units, deliver 0.7 - 1 CFM of air and can reach pressures over 500 psi. A label usually on the side says the power.

You'll need 120w or more.

CAUTION: The fridge motor has to be degassed. It is extremely important to properly evacuate all refrigerant from your refrigerator's system. Many shops will do this for free (and add it to their inventory.) This is also a good time to make sure the compressor is working. If not an expert from a local store will help you.

Once all the gas is out of the system, cut the copper tubes. There's one going in & one going out of the sealed compressor module. Use a tubing cutter for the job. Note that when cutting leave as much length of copper tubing as possible with compressor.

Try not to turn the unit upside down.

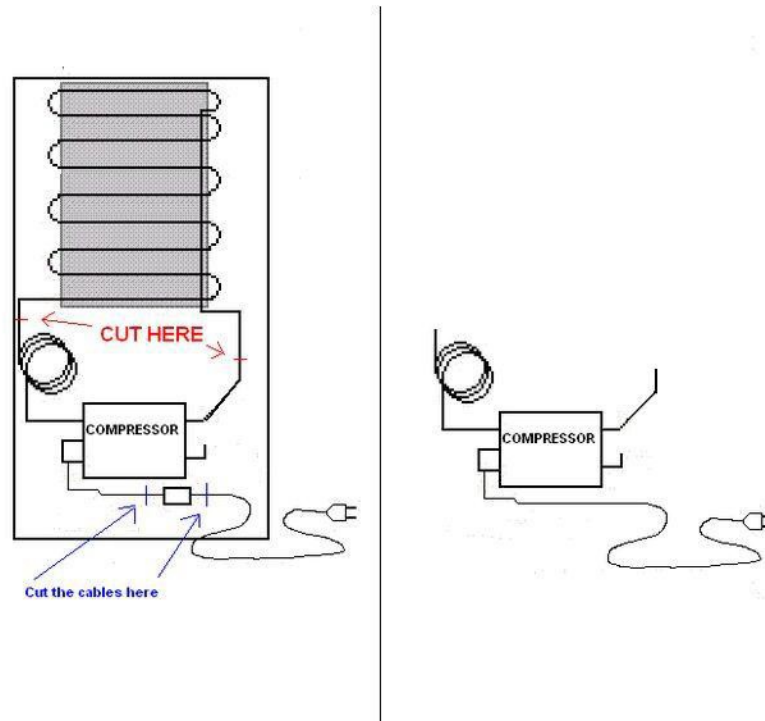

The compressor will have 3 copper tubes:

- a) The one that is sealed if for the refrigerant – leave it as it is
- b) The one with the smaller intersection (size) is for the suction (the air comes in).
- c) The other one is for the supply of compressed air (the air comes out).

NOTE: every time you'll use the compressor a very small amount of oil will come out from the tube that supply the air. So after a big amount of time you will need to add some oil again. (Don't worry about the oil coming out. Is good to have oil! I'll show you later why).

There are two power wires. One for power and the other goes to the thermostat. Cut the wires that go to thermostat. Don't forget to salvage the mains cable with the plug. Most fridges have a sort of junction box right on the side of the compressor as well as starting relay/PTC relay (all of it is house in a rectangular plastic enclosures you find on the side of the compressor). There will be a wire running from the fridge compressor to the inside of the fridge - it goes to the thermostat and powers the light inside the fridge - again the longer the length that you salvage the better.

Remove the wiring and everything else except the capacitor and pump. Connect corresponding power cord wires to the capacitor and green ground wire to base of pump.

Test if the compressor works ok.

Put a filter on the tube that the air comes in (mostly for protection like a window screen).

Now that it is all ok we are ready to go on.

2) Air tank

Here is a variety of choices

a) A cheap and loud as a jet engine compressor from a hardware store and just change the compressor unit

b) Fire extinguisher CO2 (only)

c) Portable air tank

d) Pure oxygen or nitrogen tank

e) Any other tank that can hold at least 10bar pressure.

I have an air tank from a truck! (From the airbrake system)



CAUTION: Do not use gas tank. It is not safe to use it.

NOTE: All air tanks must have at least 2 holes.

If you choose the first option then the only thing that you'll need is to remove the jet engine and adjust the fridge compressor on it.

If you choose the other ones then you have to make modifications.

Fire extinguisher CO2

This is the most difficult option you can choose because it doesn't have 2 holes and you have to make the right thread.

- a) Empty the extinguisher
- b) Unscrew its lid
- c) Wash and clean the inside of the bottle
- d) Drill 1 or 2 holes 10mm diameter

CAUTION: Don't drill holes empty extinguisher if you don't remove firstly the lid.

- e) Glues with electric welding 2 thick nuts $\frac{1}{2}$ of an inch (1/2 inch is indicative, you place the size that the pressure meters of the plugs will be)



Usually the small fire extinguishers can hold up to 16-20 bar pressure but because we have drilled holes its pressure resistance has decreased.

Now hold!

Portable air tank

Ready to use

Pure oxygen or nitrogen tank

If it has holes then go on else see fire extinguisher.

3) Other basic parts

a) Relief valve: when the pressure goes over the limit of safety we want it “opens” and releases the extra pressure. It is for safety reasons but if you don’t have it you will definitely BREAK something. Adjust it to 9 – 9.5 bar.

b) Air pressostat: This is the brain of your compressor. Buy the one with the 4 outputs and can connect with a one way valve. The pressostat is being connected between the electric power and the air compressor. Adjust it to open at 5 Bar and close at 8 Bar. This means that when the pressure in the tanks reaches the 8 Bar the pressostat “cuts” the power to the compressor. When the air pressure falls to 5 Bar the pressostat give the power again to the compressor. Most of the parts connected here.

c) Manometer 10 bar: So you can see the tank pressure.

d) One way valve or check valve: This goes between the air compressor and the air tank. For safety reasons the air compressor does not start if it indicates pressure inside it. So the one way valve pressure help the compressor by not letting the air goes back and when the pressostat stops it release the pressure inside the compressor. Without it the compressor will not start until the pressure goes to 0 bars.

e) Pressure regulator: Please buy a good one. This is one of the most important and useful thing you should have. This regulates the pressure you’ll have at the airbrush. The good one has also a manometer (must have) up to 3 bars and an air filter (must have) that traps the moisture and the oil.

f) Drain valve: This is used to drain the water and the oil that the air tank has trapped inside. Don’t freak out about the oil. It will prevent your air tank to rust and there is no way to reach at your airbrush.

g) Spare parts: like on-off small valve and connection parts like lot of teflon tape, rakors, a high pressure tube etc. Ask your local store who sells air compressor parts to help you.

h) Base: This is up to you. Use your imagination ... your favorite tools and create one.

Prefer adjust your air tank vertical and not horizontal. It is best for the rust.



4) Assembly

- a) place the air compressor and the air tank to the base
- b) connect the air pressostat with the air tank
- c) connect the air pressostat with the power and with the compressor
- d) connect the one way valve with the compressor and the air pressostat
- e) plug relief valve to the air pressostat
- f) plug the 10 bar manometer to the air pressostat
- g) connect the pressure regulator to the air pressostat
- h) connect the pressure regulator with an on-off valve
- i) Connect the air compressor to the air tank with the rakors or the high pressure tube.
- j) plug the drain valve to the air tank.

NOTE: use to connection lots of Teflon tape.

This is my draft sketch:

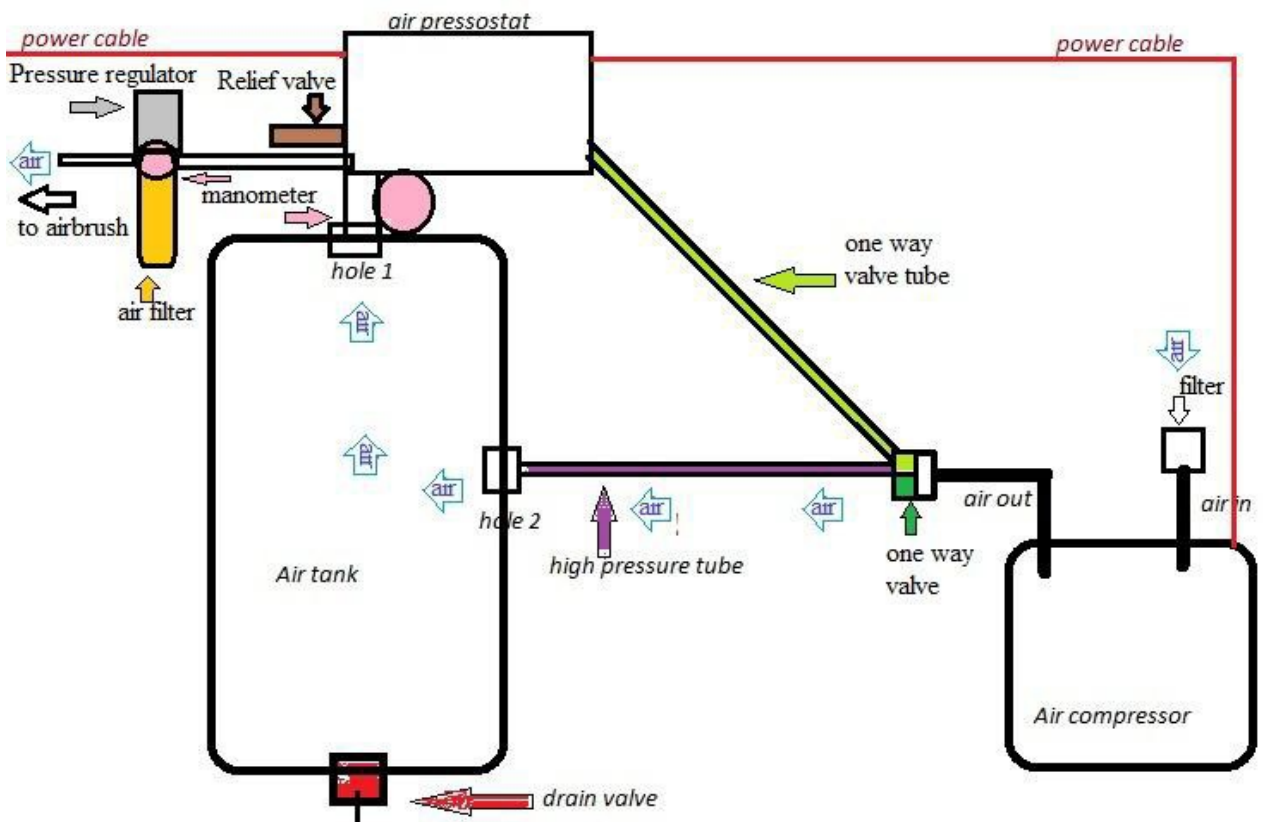

This is the one way valve:



Connect the air pressostat with the power and with the compressor:



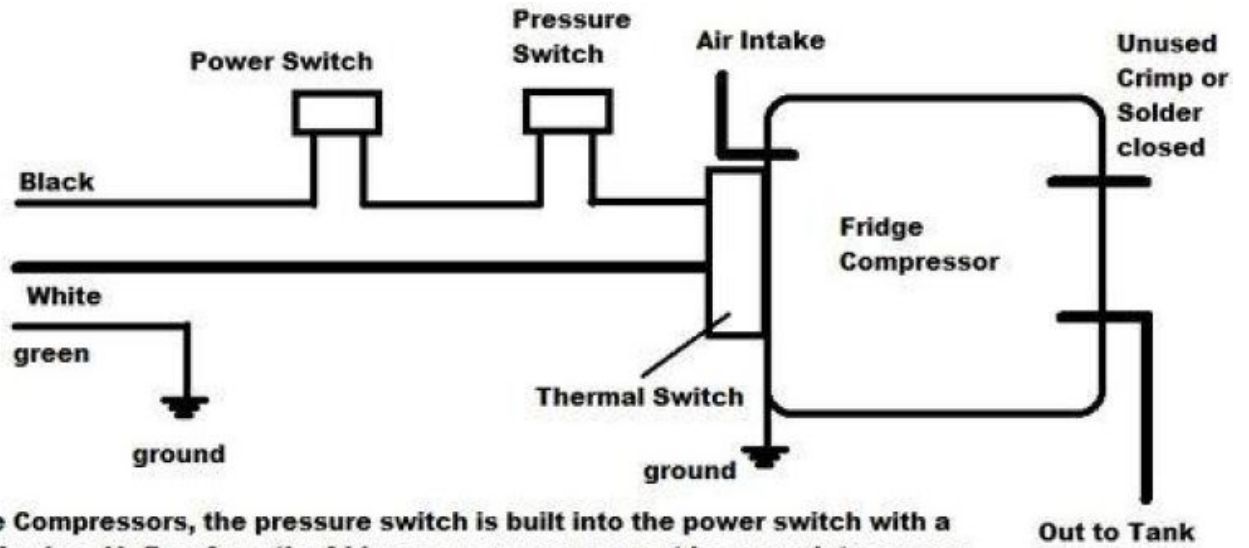

On some Compressors, the pressure switch is built into the power switch with a bleed off valve. Air flow from the fridge compressor may not be enough to engage the bleed valve causing it to leak as fast as it fills. Disabling the bleed valve will fix this issue, however it disables the pressure switch so I wouldn't recommend it. I recommend finding one with a separate pressure switch to the tank.

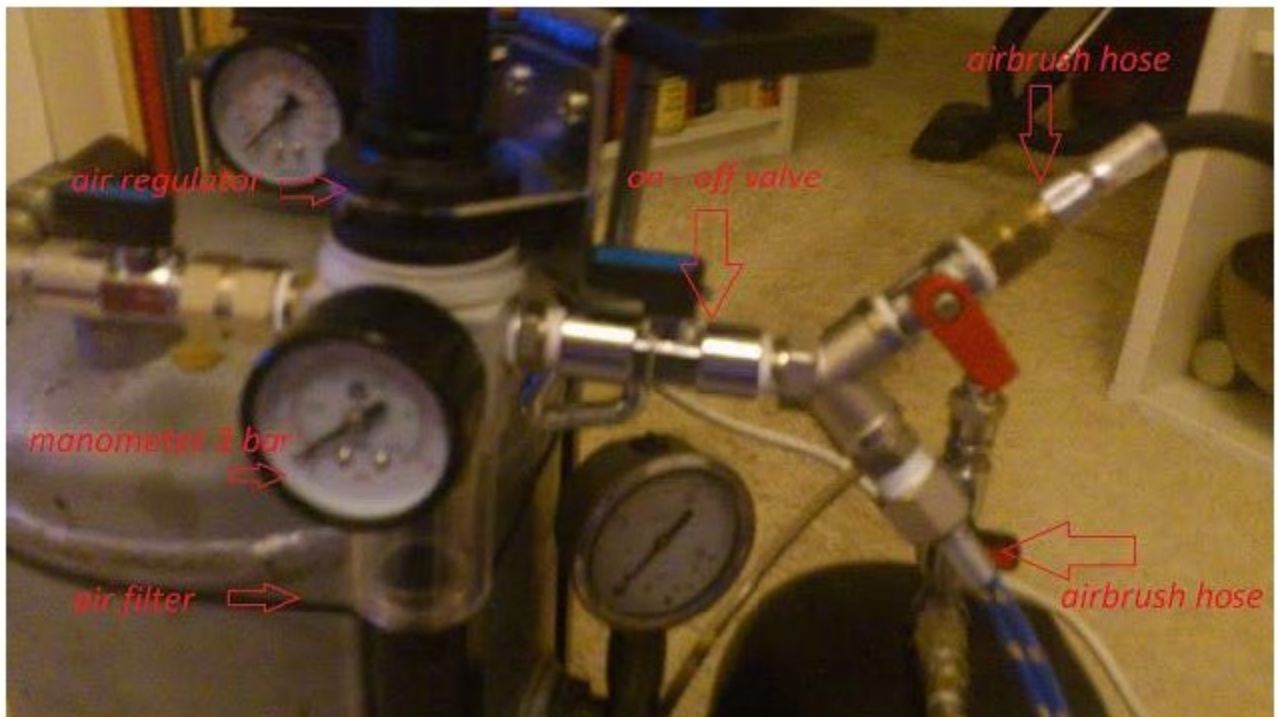

5) It's ALIVE

- a) Check that you have assemble the relief valve (**VERY IMPORTANT**)
- b) close the on-off valve so as not to lose air pressure
- c) turn on the air pressostat
- d) try to hear air leaks
- e) check the pressure if it stops at the 8 bar

6) Next you need to attach at the end of the air tube a flat nozzle:



Its purpose is to ensure that the air flow goes uniformly over the paddles of the driveshaft, as shown in the next picture:

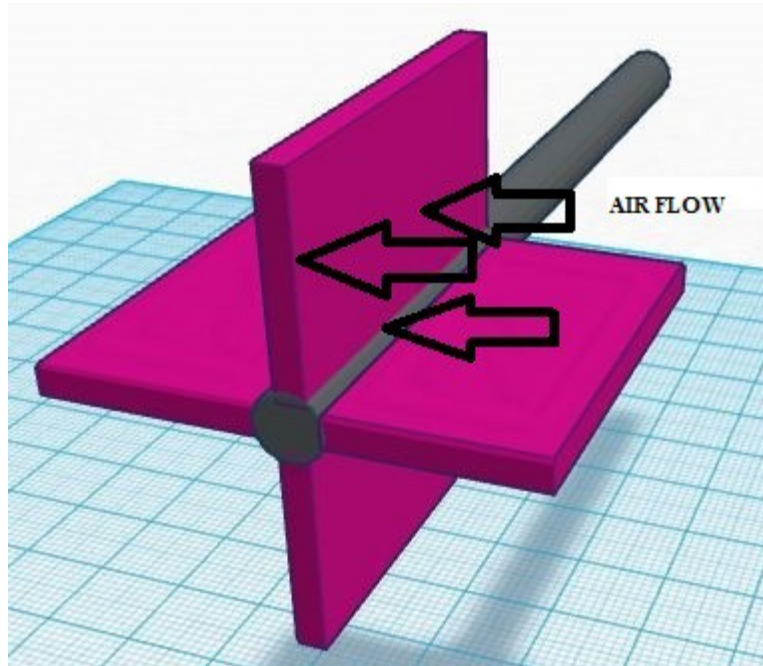

Fixing Leaks:

I can't express, enough, how important it is to make sure you don't have any leaks.

This is where the Teflon tape comes in. Fridge components don't put out a lot of volume, so any leak, no matter how small can seriously impede its fill time. Simply check every connection, and tape everything.

You're done. Everything else on the unit should stay the same and you can connect up to it as you normally would if it had a conventional compressor attached.

Simply start the air compressor and place the nozzle on the blades of the driveshaft and let it spin.

The generator will reach the 300 RPMs on its own and the air flow will increase the RPMs providing more watts.

Sit back and watch the generator produce more and more power and start counting the cash flow.